

CS350/500

High Speed Sheeter



- Roll to sheet guillotine cutter
- Cuts labels and heavy materials
- In-line and off-line operation with built-in register control
- User-friendly touch screen for smooth operation
- Cuts according to length, number of labels, or print marks

The CS350 is GM's latest high-speed guillotine sheeter providing cutting with high accuracy of $\pm 0,15$ mm.

The machine cuts web into sheets at a speed of up to 30 m/min or up to 14,000 sheets/hour depending on the selected cutting length.

The CS350 offers a web width of 350mm and operates with most digital label presses on the market. It is built for both in-line and off-line operations, and it is compatible with the entire line of GM converters.



HIGH SPEED SHEETER

This high-speed sheeter cuts sheets with a speed of up to 30 m/minute or up to 14,000 sheets/hour.

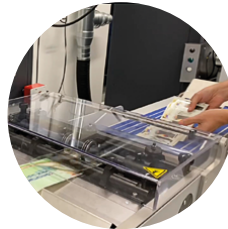

MULTIPLE USE

Cuts not only labels but other heavy materials as carton boxes for the pharmaceuticals and cosmetics sector, folding carton used for packaging in the tobacco industry and display blisters.



CS350/500

FEATURES AND OPTIONS

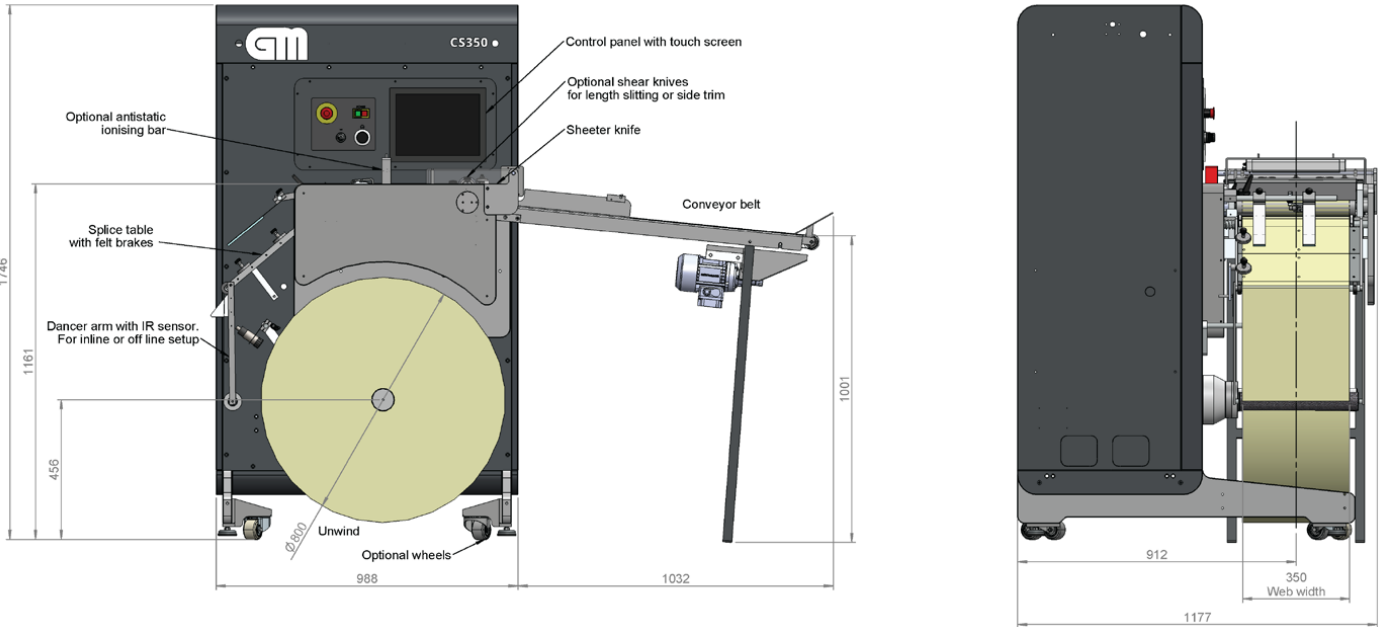

SPECIFICATIONS	METRIC	IMPERIAL
Max. web width	350/550 mm	13.8/21.7"
Min. web width	30 mm	1.18"
Max. sheet length	10 m	33 ft
Min. sheet length	10 mm	0.4"
Cutting accuracy approx.	± 0.15 mm	± 0.006"
Max. web speed	30 m/min	98 ft/min
Max. speed in sheets	14 000 sheets/hour	
Max. unwind diameter (internal)	800 mm	31.5"
Core diameter	76.2 or 152.4 mm	3 or 6"
Max. roll weight, unwinding	150 kg	331 lb
Power / Air	200 - 240V+N+PE, 13A, 6 bar	
DIMENSIONS		
W x D x H CS350	2.00x120x1,75 m	6.6x3.9x5.7 ft

The sheeter is developed to cut not only labels but other heavy materials as carton boxes for the pharmaceuticals and cosmetics sector, folding carton used for packaging in the tobacco industry and display blisters.

The sheeter can be additionally equipped with optional rotating shear knives for length slitting or side cutting, as well as wheels, allowing the machine to be easily moved when needed.

Intuitive setting of operating parameters on the touch display, and the machine cuts according to a very large variety of criterias and contains many time saving options.



Scan the QR-code to read more about the CS350/500 High speed sheeter.